

STERLING SEPARATED COMBUSTION UNITS
QVSB, QVSD & MS
HORIZONTAL CONCENTRIC VENT KIT (Option #M5)



HCVS-4

This Horizontal Concentric Vent Kit utilizes one 8 inch termination in which both the discharge flue gas and the combustion air inlet passes.

KIT CONTENTS

- (1) Part No. J37R03674 – Concentric Vent Box Assembly (See Figure 1)
- (1) Part No. J37R03604 – Inlet Air Screen
- (1) Part No. 257R03605 – Flue Terminal Assembly
- (1) Part No. H03R03612-002 – Tube Silicone Sealant
- (1) Part No. J30-03389 – Installation Instructions

VENTING REQUIREMENTS

Standard two pipe venting and concentric vent kits are certified by CSA International as venting methods for our Separated Combustion Models QVSB, QVSD and QVSF. No other venting arrangements are approved or certified for use with Sterling Separated Combustion Unit Heaters and Duct Furnaces.

All pipes are field supplied; 26 gauge single wall galvanized steel is recommended. All joints must be sealed with either high temperature silicone or aluminum foil tape.

The maximum vent length for the combustion air inlet is 50 equivalent feet. The maximum vent length for the flue gas outlet is also 50 equivalent feet. Allow 10 equivalent feet for each 90 degree elbow, and 5 equivalent feet for each 45 degree elbow for propeller units. For duct furnaces and blower units, allow 15 equivalent feet for each 90 degree elbow and 5 equivalent feet for each 45 degree elbow. See Figures 2 and 3 for typical installations of the Sterling Horizontal Concentric Vent Kit.

Table 1

Unit Capacity	Air Inlet Size	Discharge Flue Size
100, 125, 150, 175	4" (102mm)	4" (102mm)
200, 225, 250	5" (127mm)	5" (127mm)
300, 350, 400	6" (152mm)	6" (152mm)

Figure 1– Concentric Vent Box Assembly - Dimensional Data

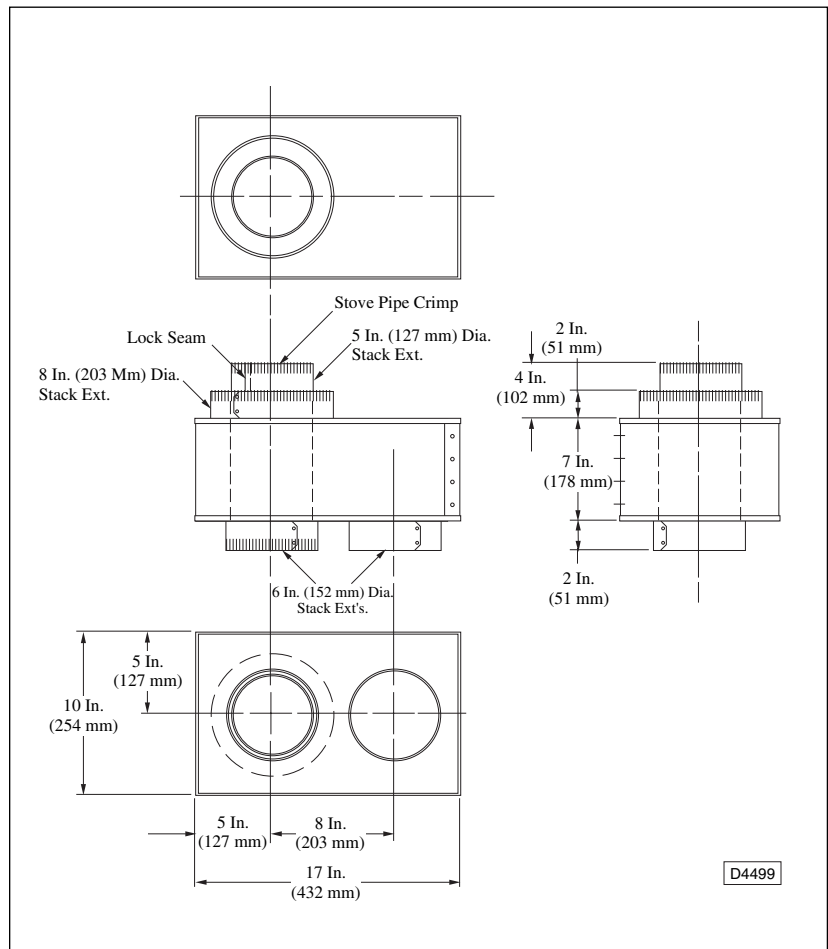

STERLING®

HVAC PRODUCTS

260 North Elm St., Westfield, MA 01085
 (413) 564-5540 Fax: (413) 562-5311
 www.sterlinghvac.com

PROJECT: _____

UNIT TAG: _____

HORIZONTAL CONCENTRIC VENT KIT (Option #M5)



Figure 2– Typical Horizontal Vent Kit Installation

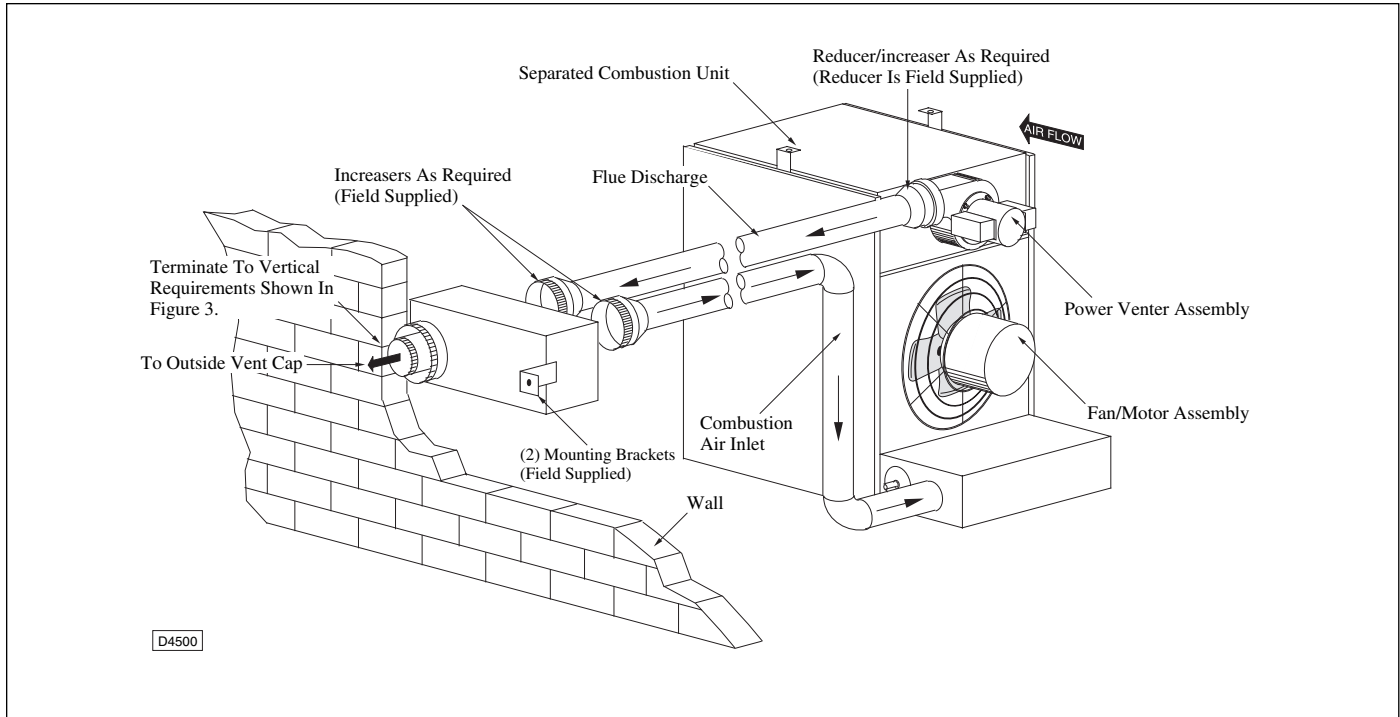

Figure 3– Typical Horizontal Vent Kit Installation Requirements

